

1xEV Opportunities in Broadband Workshop

CDMA 2004 Latin American Conference
May 28, 2004

Gerry Flynn
Director Network Strategy
Verizon Wireless

“Safe Harbor” Statement

NOTE: This presentation contains statements about expected future events and financial results that are forward-looking and subject to risks and uncertainties. For those statements, Verizon Wireless claims the protection of the safe harbor for forward-looking statements contained in the Private Securities Litigation Reform Act of 1995. The following important factors could affect future results and could cause those results to differ materially from those expressed in the forward-looking statements: materially adverse changes in economic conditions in the markets served by us, an adverse change in the ratings afforded our debt securities or those of Verizon Communications by nationally accredited ratings organizations, the effects of the substantial competition that exists in our markets, which has been intensifying, and which may intensify further as a result of local number portability regulations that allow wireless customers to retain their phone numbers when switching wireless service providers, our ability to obtain sufficient financing to satisfy our substantial capital requirements, including to fund capital expenditures, debt repayment and distributions to our owners, our ability to obtain sufficient spectrum licenses, particularly in our most densely populated areas, our ability to develop future business opportunities, including wireless data services, and to continue to adapt to the changing conditions in the wireless industry, our ability to receive satisfactory service from our key vendors and suppliers, our ability to generate additional subscribers, with acceptable levels of churn, from resellers and distributors of our service, material changes in available technology, and technology substitution that could impact the popularity and usage of our technology, our continued provision of satisfactory service to our subscribers at an acceptable cost, in order to reduce churn, the impact of continued unionization efforts with respect to our employees, regulatory developments, including new regulations that could increase our cost of doing business or reduce demand for our services, developments in connection with existing or future litigation, and changes in our accounting assumptions that regulatory agencies, including the SEC, may require or that result from changes in the accounting rules or their application, which could result in an impact on earnings.

Future Network Vision



- **Spectrally efficient air interface**
- **Smart antennas**
- **Interference cancellation**
- **Wireless backhaul**
- **All IP converged network**
- **More efficient vocoders**
- **New services (SIP based)**
- **Reduced capex per unit capacity**
- **Reduced expense per customer**

Network Evolution History

Voice
Centric

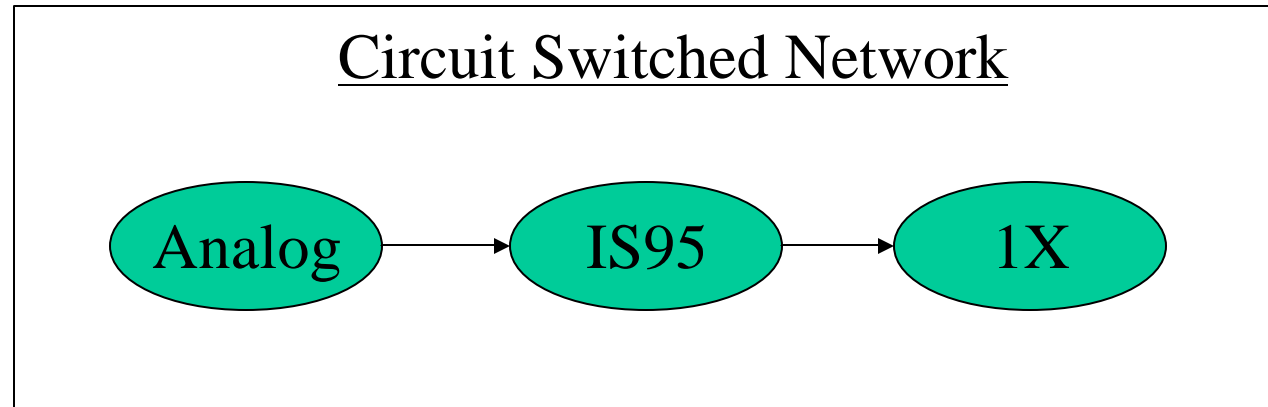

Data
Centric

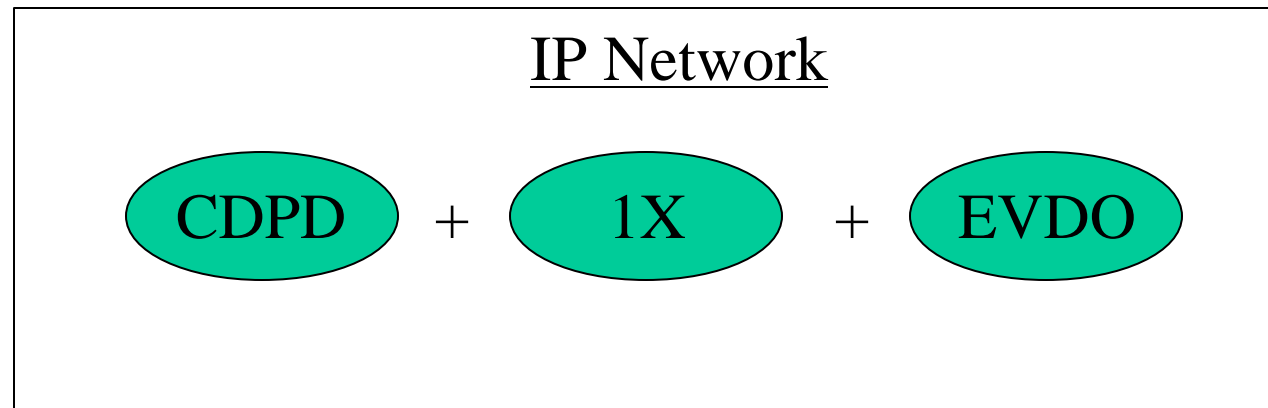

Analog Cellular Networks

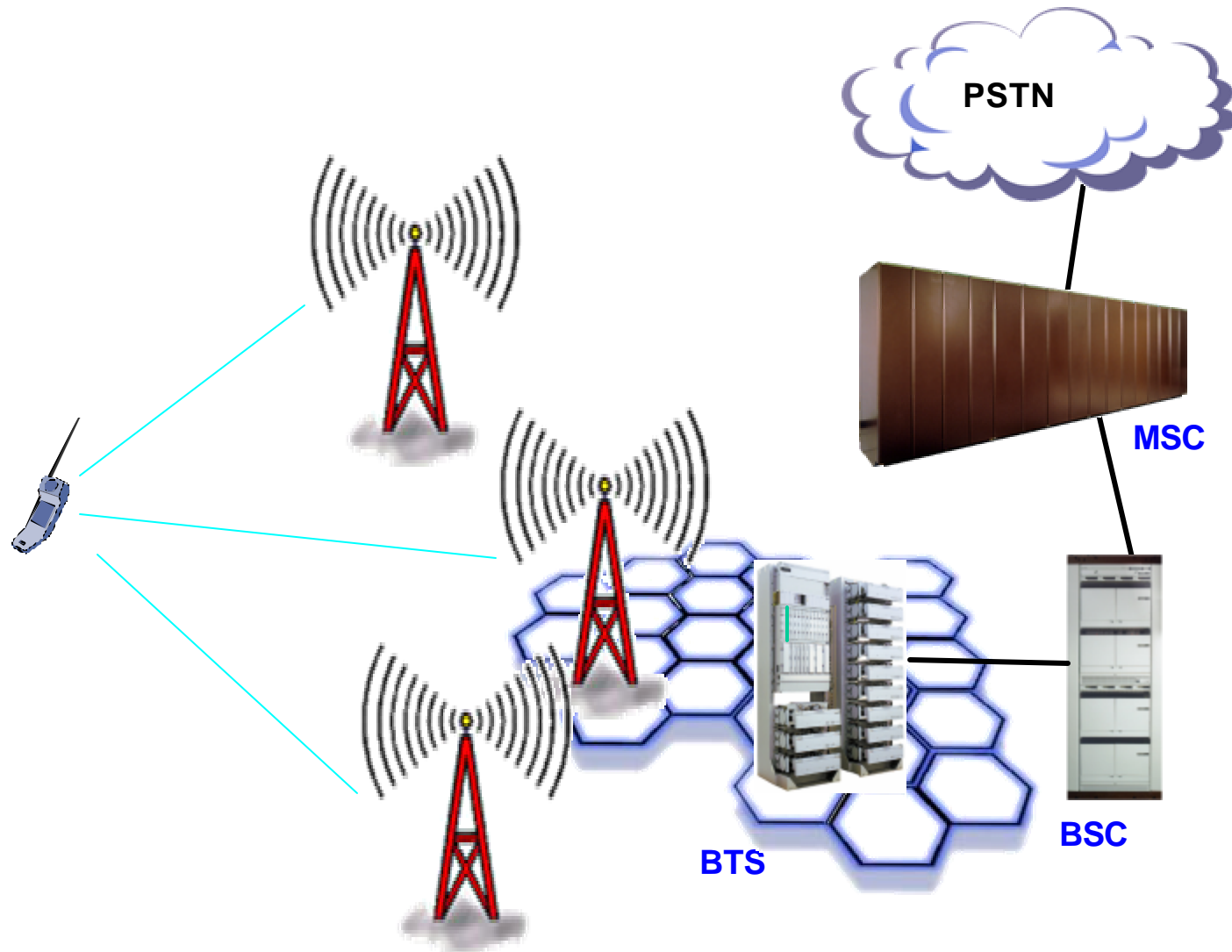

Network Direction

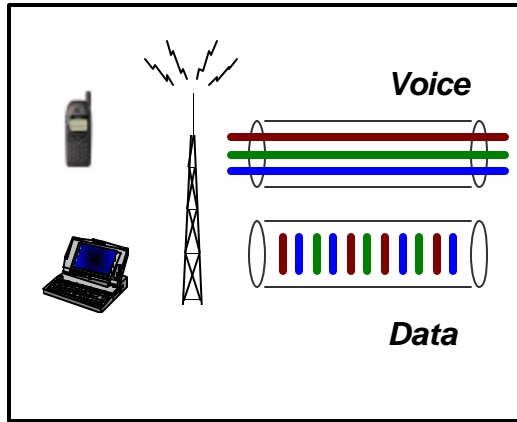

Today

- Separate networks
- CS optimum for:
 - Voice
 - SMS
 - MSC

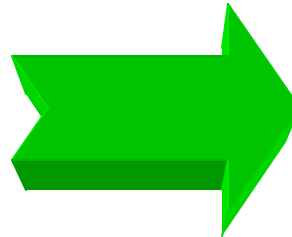

Transition

- Improve VoIP
- Deploy IPv6
- Deploy IMS + SIP
- Feature transparency
- Architecture evolution

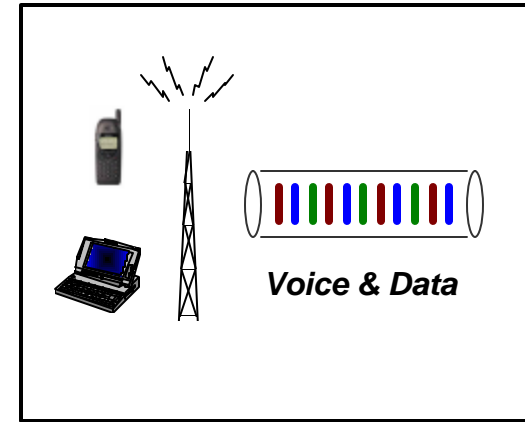

Future

- Converged network
- Multimedia services
- Best cost structure
- Radio/access technology agnostic
- IP Core

Air Interface Evolution

2002-2003

**IS 2000 Rev 0
(1XRTT)**

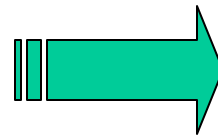

2006-2007

**IS 2000 Rev D
(?EV-DV?)**

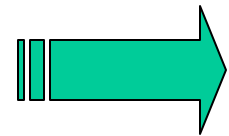

- 2X voice capacity
- 144 kbps peak
- 100% coverage

- 3.1 Mbps peak
- Supports CS voice

Air Interface Evolution

2003-2004

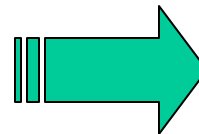
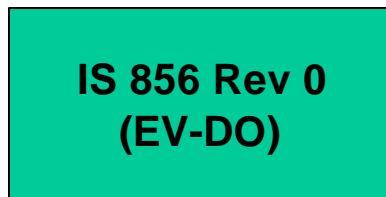

2006-2007

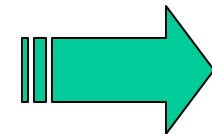
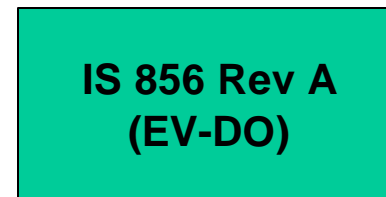

- 2.4 Mbps downlink
- 144 Kbs uplink
- All IP
- Multi-mode devices
- Handoff to 1X
- 2 markets 4Q03

- 3.1 Mbps downlink
- 1.8 Mbps uplink
- Broadcast
- Reduced latency
- QOS
- Potential for VoIP
- Converged network opportunity

1x RTT/EVDO Network Architecture

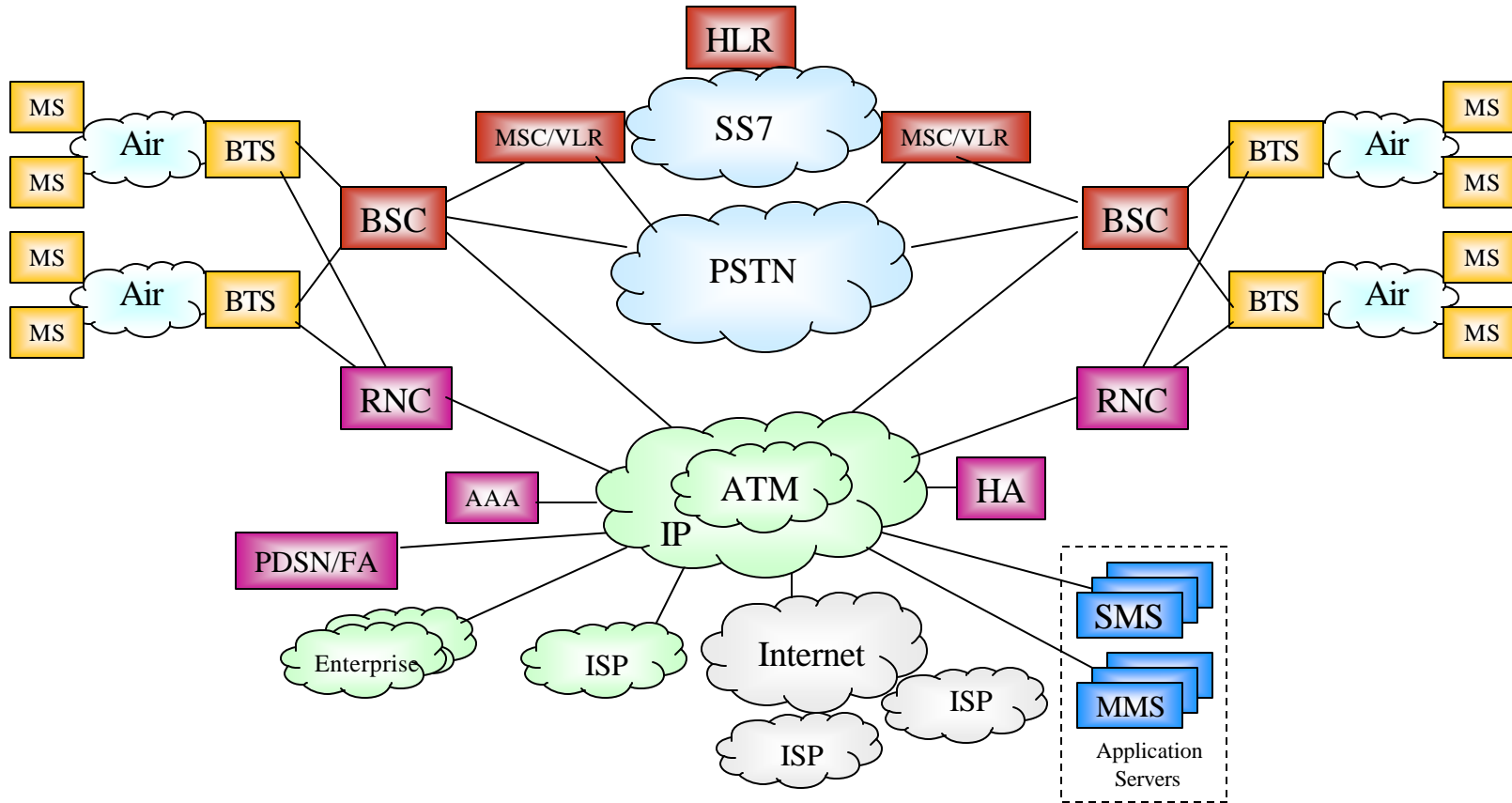

Wireless Network and Service Evolution

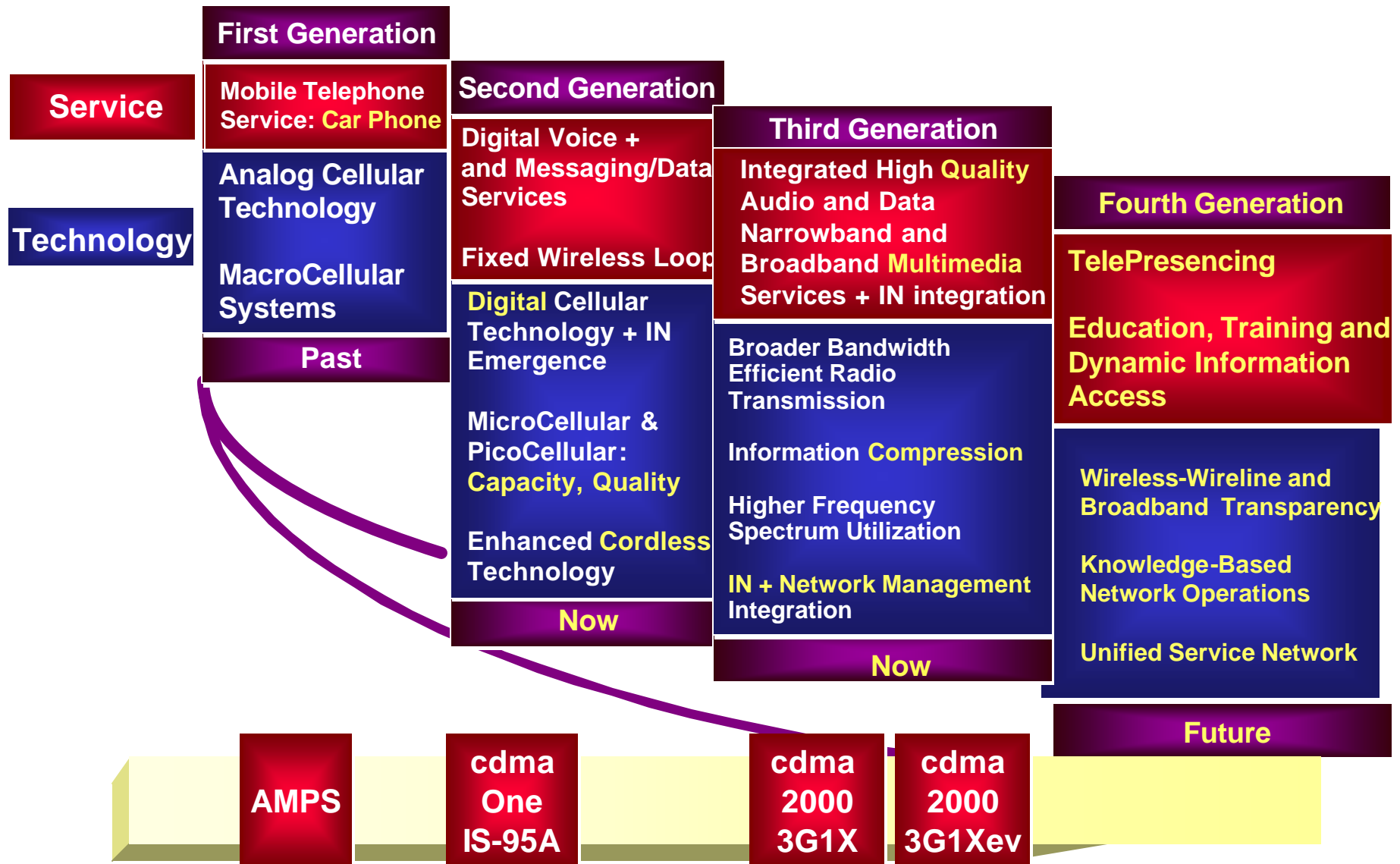

Present to the Future

■ Fundamentals

- Network Reliability
- Interoperability of Network Elements
- Scalable
- Standard Operating Environment

■ Evolution Of Network Architecture

- Market Driven Applications and Content
- Move from Centralized to Distributed Processors
- Mobility Management
- Reduce Packet overhead (Compression)
- Quality of Service

■ Key Attribute is Network Quality

- Measurable Success
 - Customer Satisfaction
 - Exceeding Customer Expectations