



OMA PoC and 3GPP2 Specifications

Tom Hiller

June 30, 2004

Outline



- **PoC Architecture Discussion**
- **3GPP2 Specification Impact**
- **PoC schedule**

PoC Reference Architecture

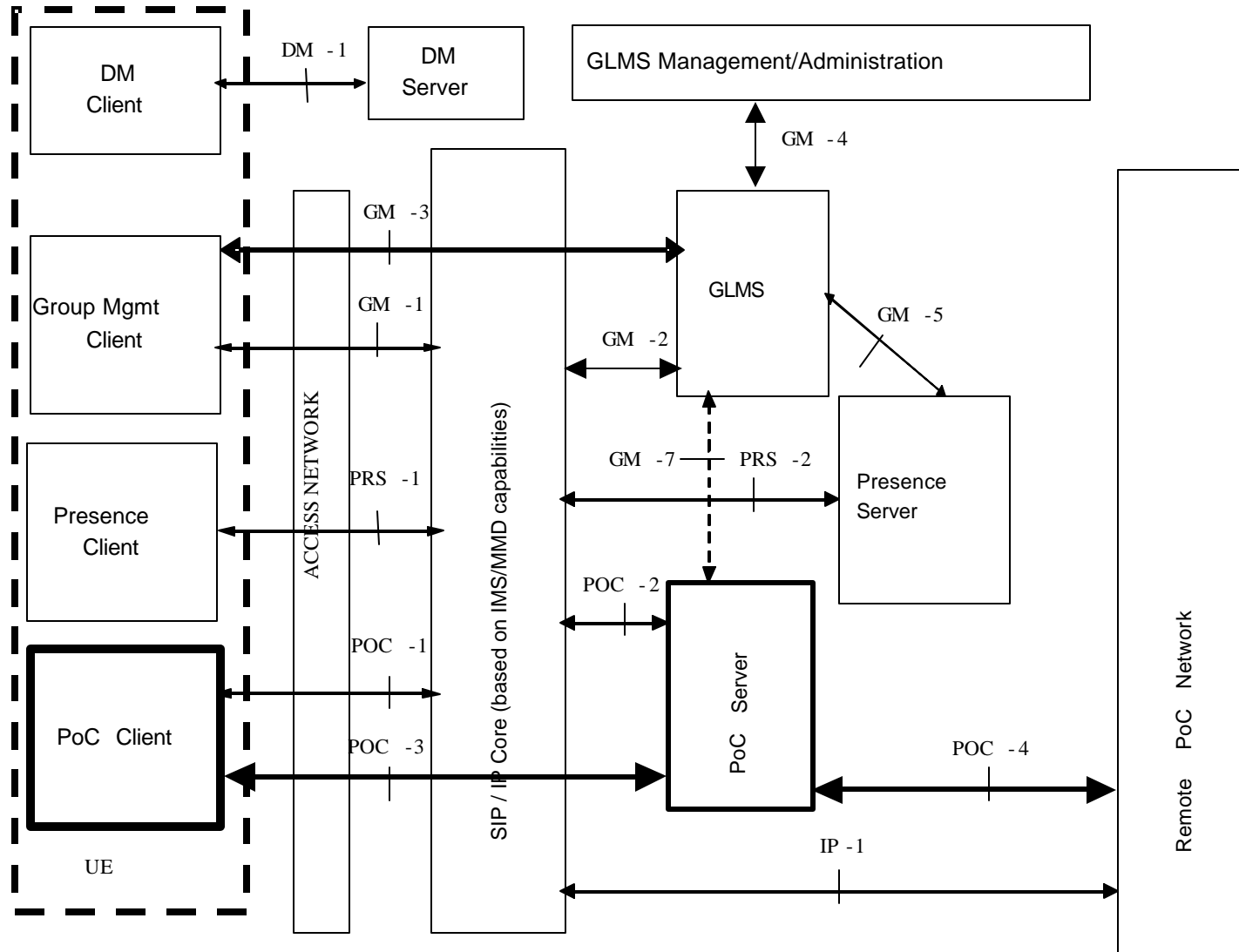

PoC Servers Types



- **Controlling PoC Server**
 - There is one of these per call
 - Call control and floor arbitration
 - Media duplication
 - Participant notification to all call members
 - Centralized call accounting
- **Participating PoC Server**
 - One per mobile regardless of how many simultaneous calls exist, i.e., to the same mobile
 - Always in the home network of the mobile
 - May relay media to the controlling PoC function; filters voice from non active calls from the mobile
 - Home network accounting

Signaling Session Establishment Models



- **Pre-established session model**
- **On-demand session model**
- **These two models work with each other seamlessly**
 - **Interaction between the two models is handled by the PoC servers**

On Demand Session Call Model



- **On demand call model**
 - **No SIP session state persisting beyond a PoC session; SIP sessions established “on demand” at the start of the PoC session**
 - **Compared to the pre-established model:**
 - **Has more and lengthier messages than the pre-established model**

On Demand Call Model

Mobility Standards

SIP, Floor Control, VOIP: All sessions dynamically setup

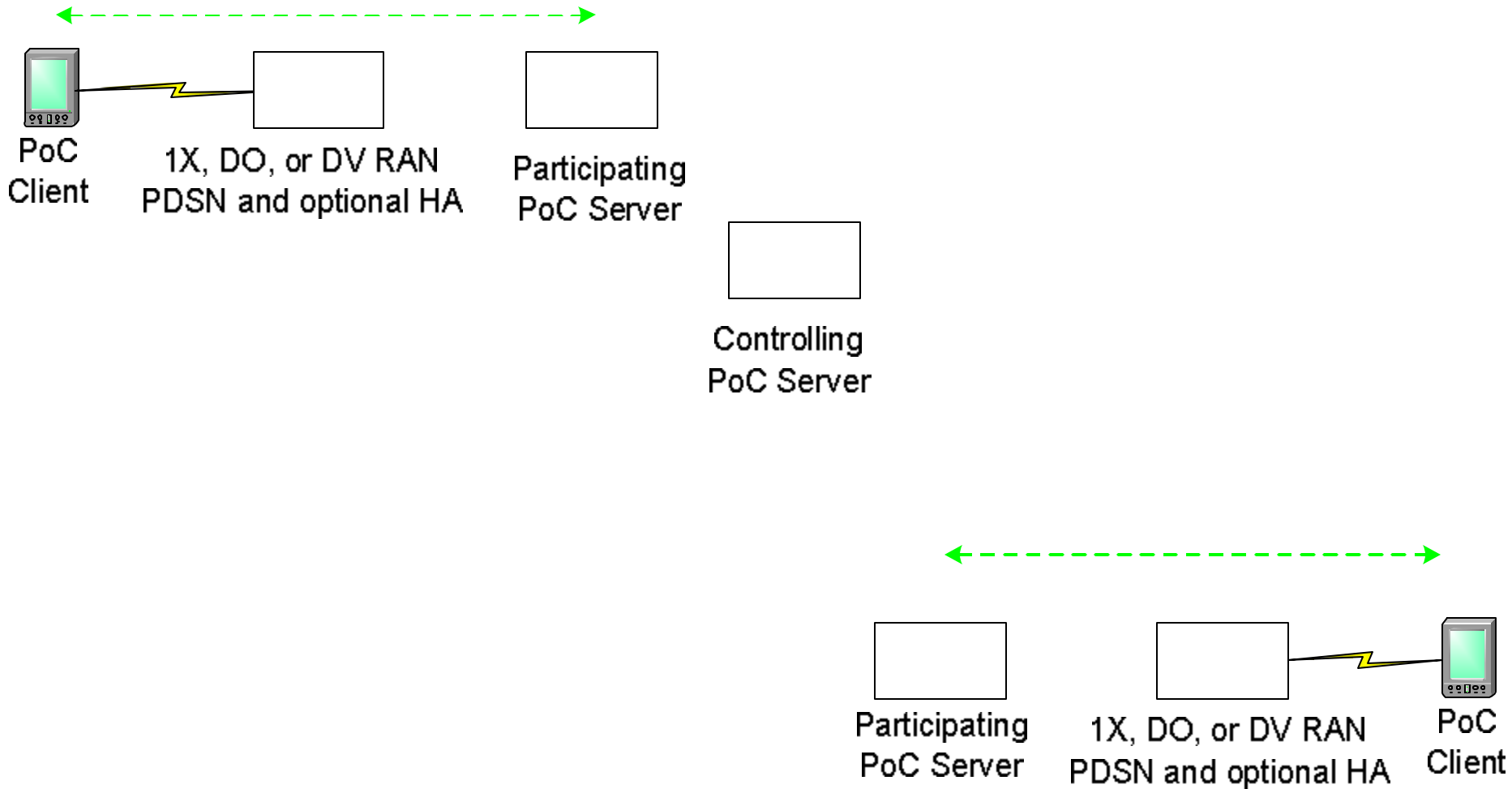

Pre-Established Session Model



- **Pre-Established call model**
 - Has static SIP sessions between the PoC client and the PoC servers; these sessions remain up continuously for during PoC service
 - These may be thought of as “half sessions” because these SIP sessions only extend to the PoC server
 - PoC servers splice these half sessions together
 - SIP half session state persists beyond a given PoC session

Pre-Established Session Model

Mobility Standards

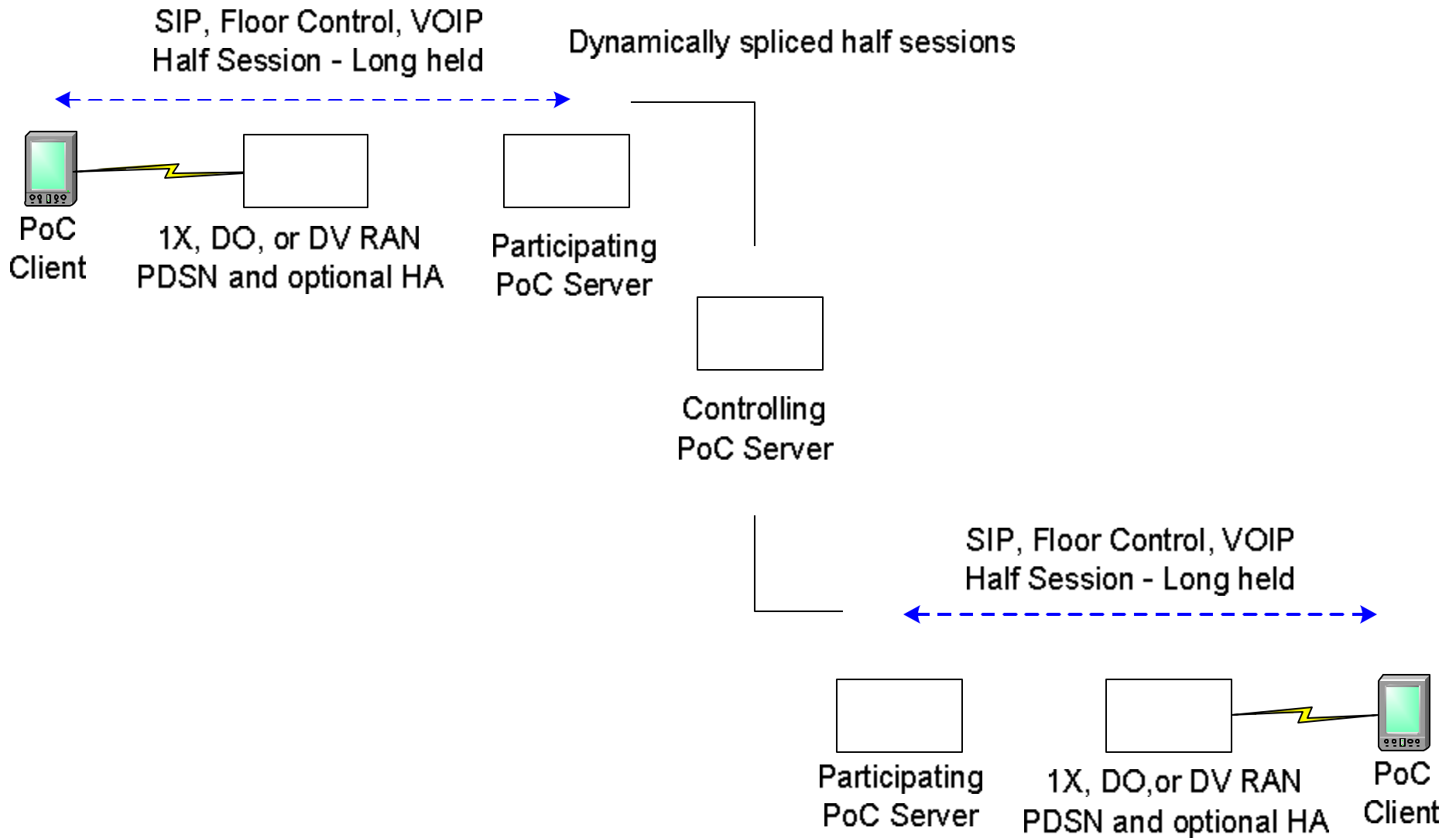

3GPP2 OMA PoC Enabler Requirements



- Known as “S10-20040607”
- In progress
- This is the CDMA2000 Stage 1 for the OMA PoC Enabler
- System signaling requirements
- Security
- Charging
- Administration
- Privacy
- Provisioning
- Identity
- Concurrent service
- PoC Client requirements
- Presence
- Interoperability
- Voice Quality
- Latency

3GPP2 Support for OMA PoC Enabler



- **This is a proposed document**
- **Specify underlying support/capability for the two signaling models at a stage 3 level**
- **This document would more or less parallel 3GPP 23.979**
- **OMA would simply reference this in it's Stage 3 documents**
- **This work is within the scope of 3GPP2, not within OMA's scope**

3GPP2 Support for OMA PoC Enabler Topics



- Review of the OMA PoC Enabler in MMD and CDMA2000 Packet Data Architectures
 - PoC session models
 - SIP Signaling
 - Talk Burst Control
 - Media and QoS
 - etc
- Codecs: EVRC, SMV(?), AMR(?)
- Transcoding requirements for PoC sessions involving CDMA2000 1X, 1xEV-DO, 1xEV-DV mobiles, including handoffs between the three CDMA2000 access technologies
 - RTP packet format based on codec frame rates and numbers of codec frames per RTP packet for 1X, 1xEV-DO, and 1xEV-DV (i.e., each)

Topics (cont'd)

Mobility Standards

- Radio bearers for 1X, 1xEV-DO, 1xEV-DV for signaling, talk burst control, and media
- Recommended guidelines for the use of short data burst (?)
- QoS authorization
- PoC specific accounting details to be included in charging records
- Etc, etc.

PoC Specification Schedule



- **OMA Schedule**
 - PoC Requirement document largely done
 - PoC Stage 2 (Architecture Document) wrapping up
 - PoC Stage 3 text in progress; scheduled to complete 4Q04
- **3GPP2**
 - 3GPP2 PoC Support specifications should be timed to finish with the OMA PoC Stage 3